

Solid Naval Brass Flanged Bearings

FORWARD STERN TUBE

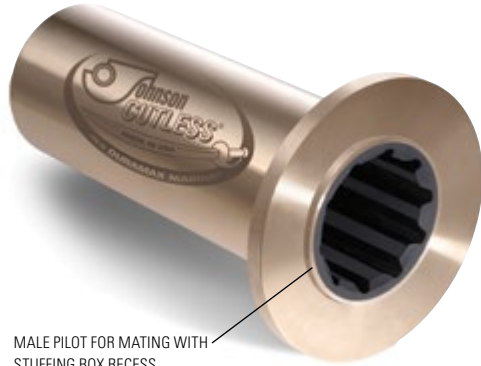

MALE PILOT FOR MATING WITH STUFFING BOX RECESS

Johnson Cutless Forward Stern Tube Flanged Bearings are made of centrifugally cast naval brass and feature a heavy metal wall and integral flange. The specially formulated nitrile rubber compound is securely bonded to metal shell and is chemical and oil resistant. The integral flange permits solid bolting of the bearing to stern tube stuffing box. The machined male pilot on the integral flange mates with the female recess of the stuffing box. Flanges are furnished UN-DRILLED unless specified. See page 18 for "Drilling Diagrams". For Split or Stepped styles see pages 14-17.

PRECAUTION:

When shrink fitting of the bearing is required, chilling must be achieved by gradual cooling to not more than minus 20°F(-28°C) using freezer or regular ice (**DO NOT DRY ICE**). NOTE: Pounding or shocking the bearing while in the chilled state could cause the rubber to separate from the shell.

Approved Bearings: Johnson Cutless® Naval Brass Flanged Bearings meet military specification MIL-DTL-17901C (SH) Class II Full-Molded type and have full type approval from The American Bureau of Shipping.

Part No.	Code	A Shaft Diameter		B Outside Diameter		C Length		D Flange Diameter		E Flange Thickness		F Metal I.D.		G Metal Thickness		M Pilot Diameter		N Pilot Thickness		Gross Wt.	
		inch	mm	inch	mm	inch	mm	inch	mm	inch	mm	inch	mm	inch	mm	inch	mm	inch	mm	lbs.	kg.
860642180	212	2 1/2	63.50	3 3/8	85.73	10	254.00	6 1/4	158.75	3/8	9.53	3 1/8	79.38	1/8	3.18	4	101.60	3/16	4.76	12	5.4
860762180	300	3	76.20	4 1/4	107.95	12	304.80	7 1/2	190.50	1/2	12.70	3 3/4	95.25	1/4	6.35	4 3/4	120.65	3/16	4.76	21	9.5
860832180	314	3 1/4	82.55	4 1/2	114.30	13	330.20	7 1/2	190.50	1/2	12.70	4	101.60	1/4	6.35	4 3/4	120.65	3/16	4.76	24	10.9
860892180	312	3 1/2	88.90	4 7/8	123.83	14	355.60	8 1/8	206.38	1/2	12.70	4 1/4	107.95	5/16	7.94	5 1/4	133.35	3/16	4.76	38	17.2
860952180	334	3 3/4	95.25	5 1/4	133.35	15	381.00	8 1/8	206.38	1/2	12.70	4 5/8	117.48	5/16	7.94	5 1/4	133.35	3/16	4.76	43	19.5
861022180	400	4	101.60	5 1/2	139.70	16	406.40	8 5/8	219.08	1/2	12.70	4 7/8	123.83	5/16	7.94	5 3/4	146.05	3/16	4.76	48	21.8
861082180	414	4 1/4	107.95	5 3/4	146.05	17	431.80	8 5/8	219.08	1/2	12.70	5 1/8	130.18	5/16	7.94	5 3/4	146.05	3/16	4.76	52	23.6
861152180	412	4 1/2	114.30	6	152.40	18	457.20	9 3/8	238.13	1/2	12.70	5 3/8	136.53	5/16	7.94	6 1/2	165.10	3/16	4.76	58	26.3
861212180	434	4 3/4	120.65	6 1/4	158.75	19	482.60	9 3/8	238.13	1/2	12.70	5 5/8	142.88	5/16	7.94	6 1/2	165.10	3/16	4.76	61	27.7
861272180	500	5	127.00	6 3/4	171.45	20	508.00	10 1/8	257.18	9/16	14.29	6	152.40	3/8	9.53	7 1/4	184.15	3/16	4.76	75	34.0
861342181	514	5 1/4	133.35	6 7/8	174.63	21	533.40	10 1/8	257.18	9/16	14.29	6 1/8	155.58	3/8	9.53	7 1/4	184.15	3/16	4.76	79	35.8
861402180	512	5 1/2	139.70	7 1/4	184.15	22	558.80	10 5/8	269.88	9/16	14.29	6 1/2	165.10	3/8	9.53	7 3/4	196.85	3/16	4.76	90	40.8
861462180	534	5 3/4	146.05	7 1/4	184.15	23	584.20	10 5/8	269.88	9/16	14.29	6 1/2	165.10	3/8	9.53	7 3/4	196.85	3/16	4.76	92	41.7
861532180	600	6	152.40	7 3/4	196.85	15	381.00	11 3/8	288.93	9/16	14.29	7	177.80	3/8	9.53	8	203.20	3/8	9.53	75	34.0
—	618	6 1/8	155.58	7 7/8	200.03	15	381.00	12 1/4	311.15	9/16	14.29	7 1/8	180.98	3/8	9.53	8	203.20	3/8	9.53	-	-
861592180	614	6 1/4	158.75	7 7/8	200.03	15	381.00	11 3/8	288.93	9/16	14.29	7 1/8	180.98	3/8	9.53	8	203.20	3/8	9.53	77	34.9
—	638	6 3/8	161.93	8 1/8	206.38	15	381.00	12 5/8	320.68	9/16	14.29	7 3/8	187.33	3/8	9.53	8 3/8	212.73	3/8	9.53	-	-
861662180	612	6 1/2	165.10	8 3/8	212.73	15	381.00	13 1/2	342.90	5/8	15.88	7 1/2	190.50	7/16	11.11	8 5/8	219.08	3/8	9.53	91	41.3
861692180	FETCH	6 5/8	168.28	8 5/8	219.08	15	381.00	13 1/2	342.90	5/8	15.88	7 5/8	193.68	1/2	12.70	8 5/8	219.08	3/8	9.53	104	47.2
—	658	6 5/8	168.28	8 1/2	215.90	15	381.00	13 1/2	342.90	5/8	15.88	7 5/8	193.68	7/16	11.11	8 5/8	219.08	3/8	9.53	-	-
861722180	634	6 3/4	171.45	8 3/4	222.25	15	381.00	13 3/4	349.25	5/8	15.88	7 7/8	200.03	7/16	11.11	9	228.60	3/8	9.53	99	44.9
—	678	6 7/8	174.63	8 7/8	225.43	15	381.00	13 3/4	349.25	5/8	15.88	8	203.20	7/16	11.11	9	228.60	3/8	9.53	-	-
861782180	700	7	177.80	9	228.60	17 1/2	444.50	13 3/4	349.25	5/8	15.88	8 1/8	206.38	7/16	11.11	9	228.60	3/8	9.53	116	52.6
—	718	7 1/8	180.98	9 1/8	231.78	17 1/2	444.50	14 1/8	358.78	5/8	15.88	8 1/4	209.55	7/16	11.11	9 5/8	244.48	3/8	9.53	-	-
861852180	714	7 1/4	184.15	9 1/4	234.95	17 1/2	444.50	14 1/8	358.78	5/8	15.88	8 3/8	212.73	7/16	11.11	9 5/8	244.48	3/8	9.53	122	55.3
—	738	7 3/8	187.33	9 1/2	241.30	17 1/2	444.50	14 1/8	358.78	5/8	15.88	8 5/8	219.08	7/16	11.11	9 5/8	244.48	3/8	9.53	-	-
861912180	712	7 1/2	190.50	9 5/8	244.48	17 1/2	444.50	14 1/2	368.30	5/8	15.88	8 3/4	222.25	7/16	11.11	10	254.00	3/8	9.53	123	55.8
—	758	7 5/8	193.68	9 3/4	247.65	17 1/2	444.50	14 1/2	368.30	5/8	15.88	8 7/8	225.43	7/16	11.11	10	254.00	3/8	9.53	-	-
861972180	734	7 3/4	196.85	9 7/8	250.83	17 1/2	444.50	14 1/2	368.30	5/8	15.88	8 7/8	225.43	1/2	12.70	10	254.00	3/8	9.53	126	57.2
—	778	7 7/8	200.03	10	254.00	17 1/2	444.50	14 7/8	377.76	5/8	15.88	9 1/8	231.78	7/16	11.11	10 3/8	263.53	3/8	9.53	-	-
862042180	HARDY	8	203.20	10 1/4	260.35	20	508.00	14 7/8	377.76	5/8	15.88	9 1/4	234.95	1/2	12.70	10 3/8	263.53	3/8	9.53	145	65.8
—	818	8 1/8	206.38	10 3/8	263.53	20	508.00	14 7/8	377.76	5/8	15.88	9 3/8	238.13	1/2	12.70	10 3/8	263.53	3/8	9.53	-	-
862102180	814	8 1/4	209.55	10 1/2	266.70	20	508.00	15 1/4	387.35	5/8	15.88	9 1/2	241.30	1/2	12.70	10 3/4	273.05	3/8	9.53	157	71.2
—	838	8 3/8	212.73	10 5/8	269.88	20	508.00	15 1/4	387.35	5/8	15.88	9 5/8	244.48	1/2	12.70	10 3/4	273.05	3/8	9.53	162	73.5
862172180	812	8 1/2	215.90	10 3/4	273.05	20	508.00	15 1/4	387.35	5/8	15.88	9 3/4	247.65	1/2	12.70	10 3/4	273.05	3/8	9.53	162	73.5
—	858	8 5/8	219.08	10 7/8	276.23	20	508.00	15 5/8	396.88	3/4	19.05	9 7/8	250.83	1/2	12.70	11 1/8	282.58	3/8	9.53	-	-
862232180	834	8 3/4	222.25	11	279.40	20	508.00	15 5/8	396.88	3/4	19.05	10	254.00	1/2	12.70	11 1/8	282.58	3/8	9.53	170	77.1
—	878	8 7/8	225.43	11 1/8	282.58	20	508.00	15 5/8	396.88	3/4	19.05	10 1/8	257.18	1/2	12.70	11 1/8	282.58	3/8	9.53	-	-
862292180	900	9	228.60	11 1/4	285.75	22 1/2	571.50	16	406.40	3/4	19.05	10 1/4	260.35	1/2	12.70	11 1/2	292.10	3/8	9.53	193	87.5
—	918	9 1/8	231.78	11 3/8	288.93	22 1/2	571.50	16	406.40	3/4	19.05	10 3/8	263.53	1/2	12.70	11 1/2	292.10	3/8	9.53	-	-
862362180	INLET	9 1/4	234.95	11 1/2	292.10	22 1/2	571.50	16	406.40	3/4	19.05	10 1/2	266.70	1/2	12.70	11 1/2	292.10	3/8	9.53	200	90.7
—	938	9 3/8	238.13	11 5/8	295.28	22 1/2	571.50	16 3/8	415.93	3/4	19.05	10 5/8	269.88	1/2	12.70	11 7/8	301.63	3/8	9.53	-	-
862422180	912	9 1/2	241.30	11 3/4	298.45	22 1/2	571.50	16 3/8	415.93	3/4	19.05	10 3/4	273.05	1/2	12.70	11 7/8	301.63	3/8	9.53	205	93.0

NOTE: Dimensions for each size bearing continue across both pages.

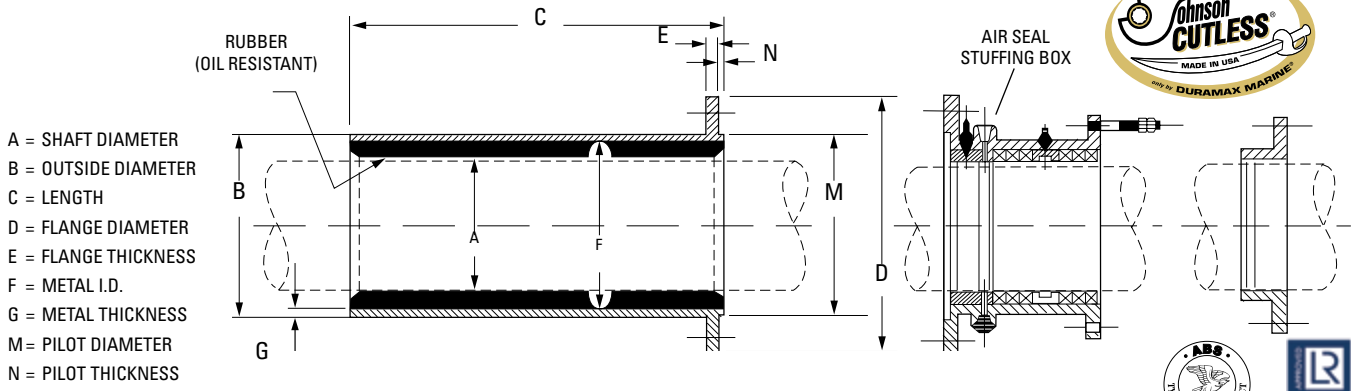

- A = SHAFT DIAMETER
- B = OUTSIDE DIAMETER
- C = LENGTH
- D = FLANGE DIAMETER
- E = FLANGE THICKNESS
- F = METAL I.D.
- G = METAL THICKNESS
- M = PILOT DIAMETER
- N = PILOT THICKNESS

Part No.	Code	A Shaft Diameter		B Outside Diameter		C Length		D Flange Diameter		E Flange Thickness		F Metal I.D.		G Metal Thickness		M Pilot Diameter		N Pilot Thickness		Gross Wt.	
		inch	mm	inch	mm	inch	mm	inch	mm	inch	mm	inch	mm	inch	mm	inch	mm	inch	mm	lbs.	kg.
862452182	958	9 5/8	244.48	11 7/8	301.63	22 1/2	571.50	16 3/8	415.93	3/4	19.05	10 7/8	276.23	1/2	12.70	11 7/8	301.63	3/8	9.53	-	-
862482180	934	9 3/4	247.65	12 1/8	307.98	22 1/2	571.50	16 7/8	428.56	3/4	19.05	11	279.40	9/16	14.29	12 3/8	314.33	3/8	9.53	217	98.4
862522180	978	9 7/8	250.83	12 1/4	311.15	22 1/2	571.50	16 7/8	428.56	3/4	19.05	11 1/8	282.58	9/16	14.29	12 3/8	314.33	3/8	9.53	-	-
862552180	1000	10	254.00	12 3/8	314.33	25	635.00	16 7/8	428.56	3/4	19.05	11 1/4	285.75	9/16	14.29	12 3/8	314.33	3/8	9.53	240	108.9
—	1018	10 1/8	257.18	12 1/2	317.50	25	635.00	17 7/8	453.96	3/4	19.05	11 3/8	288.93	9/16	14.29	12 3/4	323.85	3/8	9.53	-	-
862612180	1014	10 1/4	260.35	12 5/8	320.68	25	635.00	17 7/8	453.96	3/4	19.05	11 1/2	292.10	9/16	14.29	12 3/4	323.85	3/8	9.53	244	110.7
—	1038	10 3/8	263.53	12 3/4	323.85	25	635.00	17 7/8	453.96	3/4	19.05	11 5/8	295.28	9/16	14.29	12 3/4	323.85	3/8	9.53	-	-
862682180	1012	10 1/2	266.70	12 7/8	327.03	25	635.00	18 1/4	463.55	3/4	19.05	11 3/4	298.45	9/16	14.29	13 1/8	333.38	3/8	9.53	247	112.0
—	1058	10 5/8	269.88	13	330.20	25	635.00	18 1/4	463.55	3/4	19.05	11 7/8	301.63	9/16	14.29	13 1/8	333.38	3/8	9.53	-	-
862742180	JOLLY	10 3/4	273.05	13 1/8	333.38	25	635.00	18 1/4	463.55	3/4	19.05	12	304.80	9/16	14.29	13 1/8	333.38	3/8	9.53	250	113.4
—	1078	10 7/8	276.23	13 1/4	336.55	25	635.00	18 5/8	473.08	3/4	19.05	12 1/8	307.98	9/16	14.29	13 1/2	342.90	3/8	9.53	-	-
862802180	KETCH	11	279.40	13 1/2	342.90	27 1/2	698.50	18 5/8	473.08	3/4	19.05	12 3/8	314.33	9/16	14.29	13 1/2	342.90	3/8	9.53	300	136.1
—	1118	11 1/8	282.58	13 5/8	346.08	27 1/2	698.50	18 5/8	473.08	3/4	19.05	12 1/2	317.50	9/16	14.29	13 1/2	342.90	3/8	9.53	-	-
862872180	1114	11 1/4	285.75	13 3/4	349.25	27 1/2	698.50	19	482.60	3/4	19.05	12 5/8	320.68	9/16	14.29	13 7/8	352.43	3/8	9.53	312	141.5
—	1138	11 3/8	288.93	14	355.60	27 1/2	698.50	19	482.60	3/4	19.05	12 3/4	323.85	5/8	15.88	13 7/8	352.43	3/8	9.53	-	-
862932180	1112	11 1/2	292.10	14 1/8	358.78	27 1/2	698.50	19	482.60	3/4	19.05	12 7/8	327.03	5/8	15.88	13 7/8	352.43	3/8	9.53	326	147.9
—	1158	11 5/8	295.28	14 1/4	361.95	27 1/2	698.50	19 3/8	492.13	3/4	19.05	13	330.20	5/8	15.88	14 1/8	358.78	3/8	9.53	-	-
862992180	1134	11 3/4	298.45	14 3/8	365.13	27 1/2	698.50	19 3/8	492.13	3/4	19.05	13 1/8	333.38	5/8	15.88	14 1/8	358.78	3/8	9.53	335	152.0
—	1178	11 7/8	301.63	14 1/2	368.30	27 1/2	698.50	19 3/8	492.13	3/4	19.05	13 1/4	336.55	5/8	15.88	14 1/8	358.78	3/8	9.53	-	-
863062180	1200	12	304.80	14 3/4	374.65	30	762.00	19 3/4	501.65	3/4	19.05	13 1/2	342.90	5/8	15.88	14 1/2	368.30	3/8	9.53	360	163.3
863092180	1218	12 1/8	307.98	14 7/8	377.83	30	762.00	19 3/4	501.65	3/4	19.05	13 5/8	346.08	5/8	15.88	14 1/2	368.30	3/8	9.53	-	-
863122180	1214	12 1/4	311.15	15	381.00	30	762.00	19 3/4	501.65	3/4	19.05	13 3/4	349.25	5/8	15.88	14 1/2	368.30	3/8	9.53	373	169.2
863152180	1238	12 3/8	314.33	15 1/8	384.18	30	762.00	20 1/8	511.18	7/8	22.23	13 7/8	352.43	5/8	15.88	15 1/8	384.18	3/8	9.53	-	-
863182180	1212	12 1/2	317.50	15 1/4	387.35	30	762.00	20 1/8	511.18	7/8	22.23	14	355.60	5/8	15.88	15 1/8	384.18	3/8	9.53	394	178.7
863222180	1258	12 5/8	320.68	15 3/8	390.53	30	762.00	20 1/8	511.18	7/8	22.23	14 1/8	358.78	5/8	15.88	15 1/8	384.18	3/8	9.53	-	-
—	1234	12 3/4	323.85	15 1/2	393.70	30	762.00	20 1/2	520.70	7/8	22.23	14 1/4	361.95	5/8	15.88	15 1/2	393.70	3/8	9.53	-	-
—	1278	12 7/8	327.03	15 5/8	396.88	30	762.00	20 1/2	520.70	7/8	22.23	14 3/8	365.13	5/8	15.88	15 1/2	393.70	3/8	9.53	-	-
—	1300	13	330.20	15 7/8	403.23	32 1/2	825.50	20 1/2	520.70	7/8	22.23	14 1/2	368.30	11/16	17.46	15 1/2	393.70	3/8	9.53	-	-
—	1318	13 1/8	333.38	16	406.40	32 1/2	825.50	21	533.40	7/8	22.23	14 5/8	371.48	11/16	17.46	15 3/4	400.05	3/8	9.53	-	-
—	1314	13 1/4	336.55	16 1/8	409.58	32 1/2	825.50	21	533.40	7/8	22.23	14 3/4	374.65	11/16	17.46	15 3/4	400.05	3/8	9.53	-	-
—	1338	13 3/8	339.73	16 1/4	412.75	32 1/2	825.50	21	533.40	7/8	22.23	14 7/8	377.83	11/16	17.46	15 3/4	400.05	3/8	9.53	-	-
863442181	1312	13 1/2	342.90	16 3/8	415.93	32 1/2	825.50	21 3/8	542.93	7/8	22.23	15	381.00	11/16	17.46	16 1/4	412.75	3/8	9.53	-	-
863472180	1358	13 5/8	346.08	16 1/2	419.10	32 1/2	825.50	21 3/8	542.93	7/8	22.23	15 1/8	384.18	11/16	17.46	16 1/4	412.75	3/8	9.53	-	-
—	1334	13 3/4	349.25	16 5/8	422.28	32 1/2	825.50	21 3/8	542.93	7/8	22.23	15 1/4	387.35	11/16	17.46	16 1/4	412.75	3/8	9.53	-	-
—	1378	13 7/8	352.43	16 3/4	425.45	32 1/2	825.50	21 3/4	552.45	7/8	22.23	15 3/8	390.53	11/16	17.46	16 5/8	422.28	3/8	9.53	-	-
—	1400	14	355.60	16 7/8	428.63	35	889.00	21 3/4	552.45	7/8	22.23	15 1/2	393.70	11/16	17.46	16 5/8	422.28	3/8	9.53	-	-
—	1418	14 1/8	358.78	17	431.80	35	889.00	21 3/4	552.45	7/8	22.23	15 5/8	396.88	11/16	17.46	16 5/8	422.28	3/8	9.53	-	-
—	1414	14 1/4	361.95	17 1/8	434.98	35	889.00	22 1/8	561.98	7/8	22.23	15 3/4	400.05	11/16	17.46	17 1/4	438.15	3/8	9.53	-	-
—	1438	14 3/8	365.13	17 1/4	438.15	35	889.00	22 1/8	561.98	7/8	22.23	15 7/8	403.23	11/16	17.46	17 1/4	438.15	3/8	9.53	-	-
—	1412	14 1/2	368.30	17 1/2	444.50	35	889.00	22 1/8	561.98	7/8	22.23	16	406.40	3/4	19.05	17 1/4	438.15	3/8	9.53	-	-
—	1458	14 5/8	371.48	17 5/8	447.68	35	889.00	22 1/2	571.50	7/8	22.23	16 1/8	409.58	3/4	19.05	17 1/2	444.50	3/8	9.53	-	-
—	1434	14 3/4	374.65	17 3/4	450.85	35	889.00	22 1/2	571.50	7/8	22.23	16 1/4	412.75	3/4	19.05	17 1/2	444.50	3/8	9.53	-	-
—	1478	14 7/8	377.83	17 7/8	454.03	35	889.00	22 3/4	577.85	7/8	22.23	16 3/8	415.93	3/4	19.05	17 3/4	450.85	3/8	9.53	-	-
—	1500	15	381.00	18	457.20	35	889.00	22 3/4	577.85	7/8	22.23	16 1/2	419.10	3/4	19.05	17 3/4	450.85	3/8	9.53	-	-

NOTE: Dimensions for each size bearing continue across both pages.

NAVAL BRASS FLANGED